

Key-ring Inserts and Key-ring Studs

Kelox® inserts and studs are high performance threaded products that typically require smaller diameter installation holes than other solid bushing inserts and studs. This translates into overall reduced boss sizes and weight savings. The Kelox® fasteners incorporate a pair of self-broaching keys joined by an integral ring that facilitates the driving of the keys into the structure.

While exhibiting the same features and benefits as standard key-locked inserts, Kelox® inserts and studs have internal ring attaching keys. This provides additional support while installing keys, but requires a small counterbore to allow the ring to sit flush with the top surface of parent material.

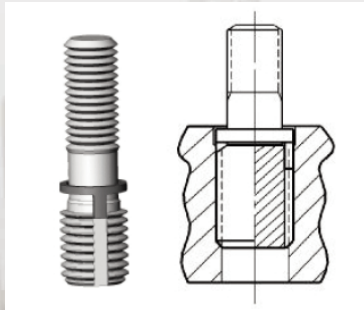
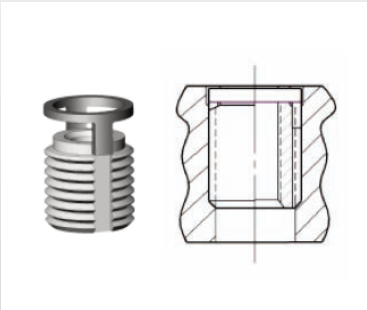

Key-ring Inserts (Kelox®)

NAS1839–NAS1840
 SL9202/4 SL9214/5
 SL9208 SL9325
 SL9211 69825-(XX)-(X)

Key-ring Studs (Kelox®)

MIL-S-45933/1-(XX)
 MIL-S-45933/2-(XX)
 NAS1841–NAS1854
 NAS1860–NAS1863

J1130P/31P-(XX) SL9324
 J1172P-(XX) SL9328
 J1179P-(XX) V:002 889-(XX)
 J1196P-(XX) 1798M81G
 J1206P/08P-(XX) 3020T29P-(XX)
 KL5510154-(XX)-(XX) 4031T42P-(XX)
 SL9301–SL9302 4058T30P-(XX)
 SL9304 5031T71P-(XX)
 SL9306 5046753P-(XX)
 SL9308–SL9316 69544P14-(XX)
 SL9320 9977013–249G-(XX)

Key-ring Features

- Products utilize high strength keys for self-broaching into harder materials
- Key-ring product is manufactured in a variety of materials including A286, Incone® and Titanium.
- The key-ring is made from 420 Cres material that will self-broach in materials upto 40 HRC nut end thread.
- Internal thread locking features are available in each material type.

Key-locked Assemblies

SLJ1216P04
 SLJ970P03
 SLJ970P04

Use Kelox® inserts and studs anywhere strong, long lasting threadforms are required in a variety of parent materials, such as magnesium and aluminum. Kelox® studs are an ideal solution when the use of standard bolts becomes impractical or impossible. Typical applications frequently include, but are not limited to, engine or power transmission components.

Fastener Dimensions Inc. is an independent distributor of the many brand name products that we sell and that appear in our literature.

* Kelox® is a registered trademark of Alcoa® (AFS). ** Incone® is a registered trademark of Incoalloys International.